

- 1.) Muffe mit Bogenrohr WW
- 2.) Muffe mit Schicht-U KW
- 3.) Muffe Zirkulation
- 4.) Flansch mit Anode auf Deckel
- 5.) Flansch mit Dichtung, Deckel und Schrauben
- 6.) Muffe Fühler
- 7.) Muffe Thermometer
- 8.) Muffe Entlüftung
- 9.) Muffe Anode
- 10.) Muffe Fühler
- 11.) Muffe, GWT

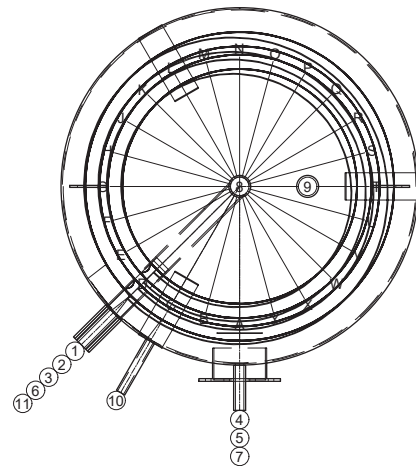

Es handelt sich um schematische Darstellungen - detaillierte Informationen entnehmen Sie bitte den folgenden Tabellen!

- Isolation:** - Type 300 – 600: 75 mm fix geschäumt mit Skai-Mantel silbergrau
 - Type 750 – 1250: 130 mm Heat-Blocker-Isolation mit Polystyrol-Mantel silbergrau
 - Type 1500 - 2000: 160 mm Heat-Blocker-Isolation mit Polystyrol-Mantel silbergrau

Type	EWS1/300 WP		EWS1/400 WP		EWS1/500 WP		EWS1/600 WP		EWS1/750 WP		EWS1/1000 WP		EWS1/1250 WP		EWS1/1500 WP		EWS1/2000 WP	
Inhalt	292,3 l		385,6 l		461,0 l		578,4 l		779,3 l		895,3 l		1247 l		1375,2 l		1964,3 l	
Ø roh/isoliert	-	750	-	750	-	750	-	800	790	1050	790	1052	900	1162	1000	1322	1100	1422
Höhe/isoliert	-	1340	-	1700	-	1960	-	2020	1770	1900	2150	2150	2140	2270	2050	2210	2350	2510
Kippmass	1536		1858		2099		2173		1804		2052		2175		2088		2394	
e.NLV ⁽¹⁾	197		116		120		196		265		306		483		620		979	
GWT	3,2 m ²		5,0 m ²		6,2 m ²		6,0 m ²		7,0 m ²		8,0 m ²		8,0 m ²		9,0 m ²		12,0 m ²	
EU-WHV ⁽²⁾	58,1 W B		73,0 W B		80,2 W B		91,2 W		114,2 W		122,1 W		145,3 W		122,8 W		156,6 W	
Gewicht	116 kg		161 kg		190 kg		202 kg		252 kg		348 kg		356 kg		446 kg		650 kg	

Anschlusshöhen und -dimensionen

	A		B		C		D		E		F		G		H		I		J		K		L	
A	79	1"	79	1"	79	1"	280	1 1/4"	220	1 1/4"	220	1 1/4"	180	1 1/2"	315	1 1/2"	260	1 1/2"						
B	225	1 1/4"	225	1 1/4"	225	1 1/4"	370	1 1/4"	320	1 1/4"	320	1 1/4"	290	1 1/4"	435	1 1/2"	400	1 1/2"						
C	370	Ø 180	345	Ø 180	345	Ø 180	520	Ø 180	430	Ø 180	430	Ø 180	480	Ø 240	575	Ø 240	580	Ø 290						
D	370	1/2"	590	1/2"	700	1/2"	520	1/2"	450	1/2"	450	1/2"	480	1/2"	665	1/2"	650	1/2"						
E	835	1 1/4"	1125	1 1/4"	1335	1 1/4"	1290	1 1/4"	1150	1 1/4"	1280	1 1/4"	1250	1 1/4"	1185	1 1/2"	1220	1 1/2"						
F	-		1230	Ø 180	1435	Ø 180	1380	Ø 180	1230	Ø 180	1395	Ø 180	1380	Ø 180	1260	Ø 180	1320	Ø 180						
G	935	1/2"	1230	1/2"	1435	1/2"	1380	1/2"	1250	1/2"	1395	1/2"	1380	1/2"	1300	1/2"	1400	1/2"						
H	600	3/4"	900	3/4"	1040	3/4"	1100	3/4"	1350	1"	1495	1"	1510	1"	1450	1"	1520	1"						
I	1160	1"	1541	1"	1801	1"	1680	1 1/4"	1480	1 1/4"	1735	1 1/4"	1700	1 1/4" ⁽³⁾	1690	1 1/2"	1990	1 1/2"						
J	1020	1/2"	1385	1/2"	1650	1/2"	1680	1/2"	1480	1/2"	1735	1/2"	1860	1/2"	1690	1/2"	1990	1/2"						
K	-		1600	1 1/4"	1860	1 1/4"	1920	1 1/4"	1770	1 1/4"	2020	1 1/4"	2140	1 1/4"	2050	1 1/4"	2350	1 1/4"						
L	1220	1 1/4" ⁽³⁾	1600	1 1/4" ⁽³⁾	1860	1 1/4" ⁽³⁾	1920	1 1/4" ⁽³⁾	1770	1 1/4" ⁽³⁾	2020	1 1/4" ⁽³⁾	2140	1 1/4" ⁽³⁾	2050	1 1/4" ⁽³⁾	2350	1 1/4" ⁽³⁾						

8 Energieeffizienzklasse ⁽¹⁾ elektrisches Nachladevolumen ⁽²⁾ Warmhalteverlust in W/h (EU) ⁽³⁾ Anode verbaut

Leistungsdaten Glattrohrwärmetauscher

Speicher	Register Heizfläche m ²	Kessel		WW-Leistung TWW = 45 °C					WW-Leistungen TWW = 60 °C				
				Heizwasser		Spitzenleistung	Dauerleistung TKW = 10 °C		Heizwasser		Spitzenleistung	Dauerleistung TKW = 10 °C	
		Vorlauf	Rücklauf	primär	Δ p		l/10 min*	l/h	kW	primär		Δ p	l/10 min*
		°C	°C	m ³ /h	kPa	m ³ /h				kPa			
EWS 1 300 WP	3,2 doppelt gewendelt	50	40	1,72	1	64	491	20	-	-	-	-	-
		60	50	4,47	5,4		1278	52	-	-	-	-	-
		70	60	6,88	10,7		1965	80	4,82	6	64	963	56
		80	70	9,63	19,7		2752	112	8,77	19,8	64	1754	102
EWS 1 400 WP	5,0 doppelt gewendelt	50	40	3,1	4,6	85	885	36	-	-	-	-	-
		60	50	7,22	19,9		2064	84	-	-	-	-	-
		70	60	8,6	19,6		2457	100	7,4	19,3	85	1479	86
		80	70	9,63	19,7		2752	112	8,77	19,8	85	1754	102
EWS 1 500 WP	6,2 doppelt gewendelt	50	40	3,96	8,8	101	1130	46	-	-	-	-	-
		60	50	7,22	19,9		2064	84	-	-	-	-	-
		70	60	8,6	19,6		2457	100	7,4	19,3	101	1479	86
		80	70	9,63	19,7		2752	112	8,77	19,8	101	1754	102
EWS 1 600 WP	6,0 doppelt gewendelt	50	40	3,78	7,8	147	1081	44	-	-	-	-	-
		60	50	7,22	19,9		2064	84	-	-	-	-	-
		70	60	8,6	19,6		2457	100	7,4	19,3	147	1479	86
		80	70	9,63	19,7		2752	112	8,77	19,8	147	1754	102
EWS 1 750 WP	7,0 doppelt gewendelt	50	40	4,47	12,2	244	1278	52	-	-	-	-	-
		60	50	7,22	19,9		2064	84	-	-	-	-	-
		70	60	8,6	19,6		2457	100	7,4	19,3	244	1479	86
		80	70	9,63	19,7		2752	112	8,77	19,8	244	1754	102
EWS 1 1000 WP	8,0 doppelt gewendelt	50	40	5,25	18,8	321	1499	61	-	-	-	-	-
		60	50	7,22	19,9		2064	84	-	-	-	-	-
		70	60	8,6	19,6		2457	100	7,4	19,3	321	1479	86
		80	70	9,63	19,7		2752	112	8,77	19,8	321	1754	102
EWS 1 1250 WP	8,0 doppelt gewendelt	50	40	5,25	18,8	431	1499	61	-	-	-	-	-
		60	50	7,22	19,9		2064	84	-	-	-	-	-
		70	60	8,6	19,6		2457	100	7,4	19,3	431	1479	86
		80	70	9,63	19,7		2752	112	8,77	19,8	431	1754	102
EWS 1 1500 WP	9,0 dreifach gewendelt	50	40	5,68	7,8	471	1622	66	-	-	-	-	-
		60	50	10,84	19,8		3096	126	-	-	-	-	-
		70	60	12,99	19,9		3710	151	11,18	19,7	471	2236	130
		80	70	14,88	19,9		4250	173	13,59	19,9	471	2717	158
EWS 1 2000 WP	12,0 dreifach gewendelt	50	40	7,91	19,1	663	2260	92	-	-	-	-	-
		60	50	10,84	19,8		3096	126	-	-	-	-	-
		70	60	12,99	19,9		3710	151	11,18	19,7	663	2236	130
		80	70	14,88	19,9		4250	173	13,59	19,9	663	2717	158

*berechnet auf den oberen Fühler